

CNC Controller Schematic

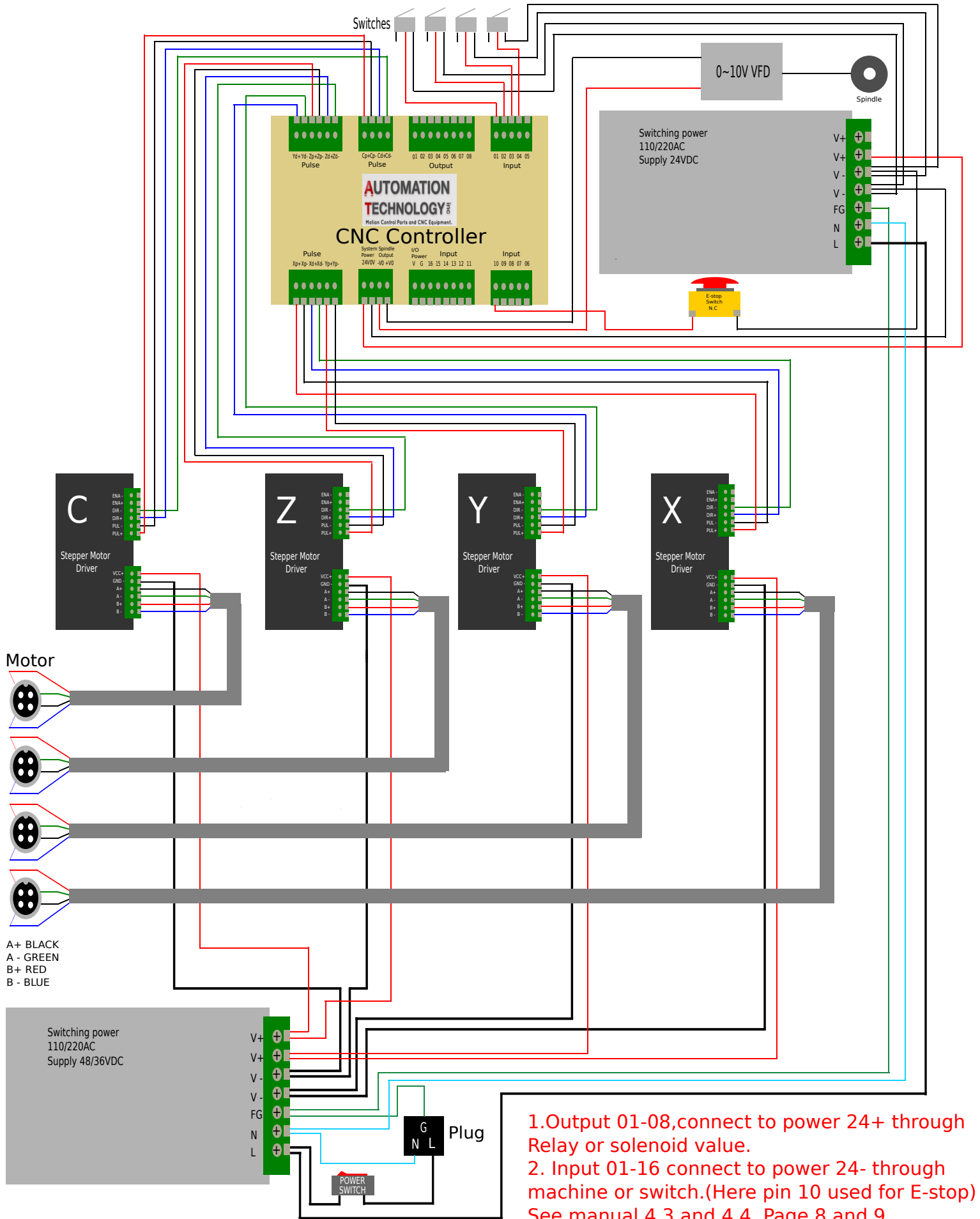

A+ - BLACK
 A - GREEN
 B+ - RED
 B - BLUE

1. Output 01-08, connect to power 24+ through Relay or solenoid valve.
 2. Input 01-16 connect to power 24- through machine or switch. (Here pin 10 used for E-stop) See manual 4.3 and 4.4, Page 8 and 9.
- <http://www.automationtechnologiesinc.com>