

Z axis stepper motor driver    Y axis stepper motor driver    X axis stepper motor driver

D D P P    D D P P    D D P P  
 I I U U    I I U U    I I U U  
 R R L L    R R L L    R R L L  
 - + - +    - + - +    - + - +

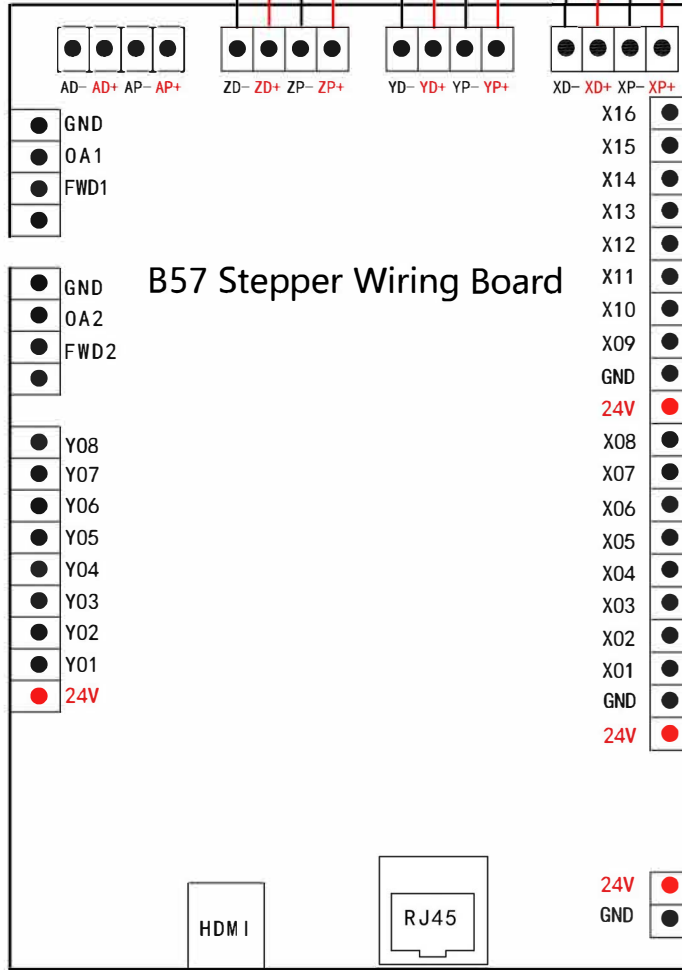

Ground ● GND  
 Analog voltage 1 ● OA1  
 Spindle forward signal 1 ● FWD1  
 System reserved ●

Ground ● GND  
 Analog voltage 2 ● OA2  
 Spindle forward signal 2 ● FWD2  
 System reserved ●

release/accept tool holder signal ● Y08  
 Reserved output signal ● Y07  
 Dust hood open/close output signal ● Y06  
 Reserved output signal ● Y05  
 Reserved output signal ● Y04

Alarm lamp output ● Y03  
 Spindle FWD 2 ● Y02  
 Spindle FWD 1 ● Y01

24V + ● 24V

X16 ● Spindle with or without tool signal  
 X15 ● Dusthood open signal  
 X14 ● Tool accepted signal  
 X13 ● Tool released signal  
 X12 ● Waiting spindle off signal  
 X11 ● Cylinder put in place signal (Not enabled)  
 X10 ● Manually release/accept tool signal  
 X09 ● Pump pressure sensor signal  
 GND ● 24V DC  
 24V + ● Power supply output signal  
 X08 ● Reserved input signal  
 X07 ● Reserved input signal  
 X06 ● Servo driver alarm  
 X05 ● Spindle alarm signal  
 X04 ● Tool setting  
 X03 ● Z home signal  
 X02 ● Y home signal  
 X01 ● X home signal  
 GND ● 24V DC  
 24V + ● Power supply output signal  
 24V + ● 24V DC  
 GND ● Power supply input signal

### Inverter Wiring

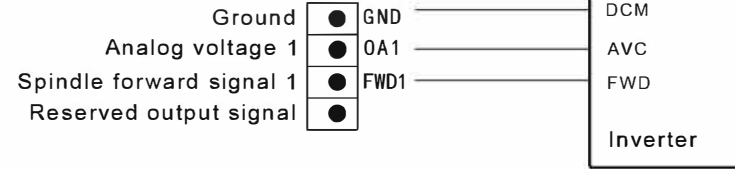

### Mechanical HOME switch

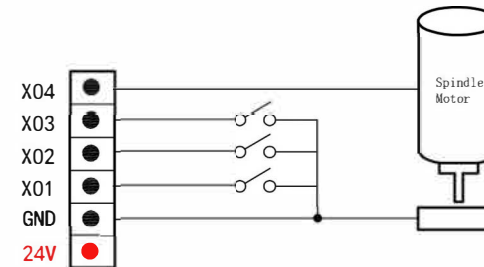

### Photoelectric HOME switch

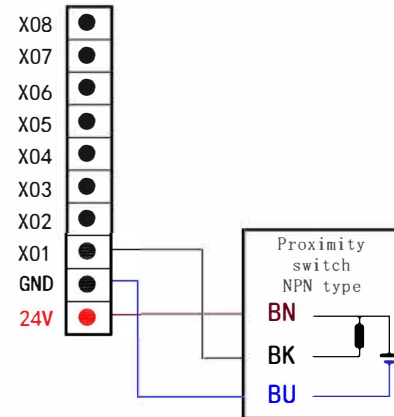

Model No.	B57 ATC motion control system