

Dimension:
Unit=mm

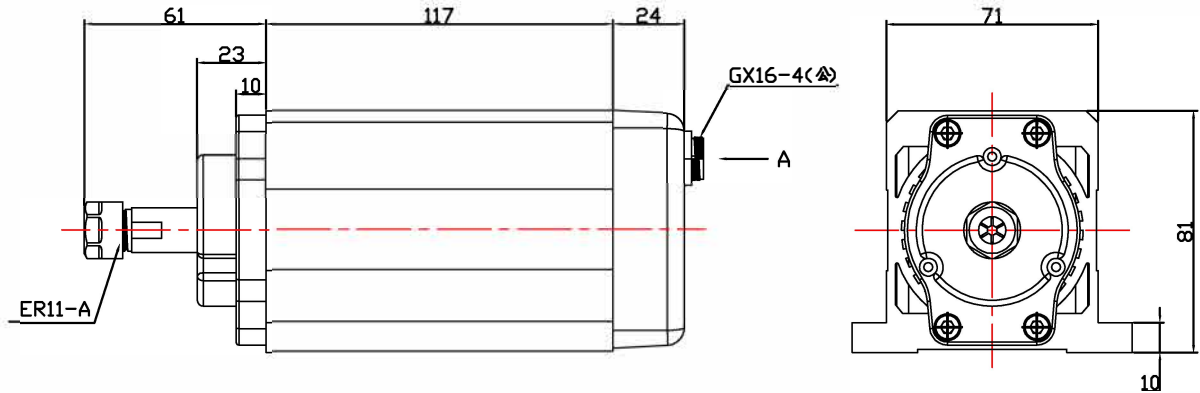

A 向视图
2:1

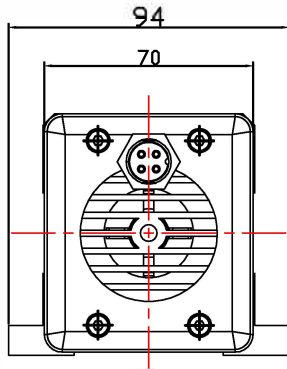
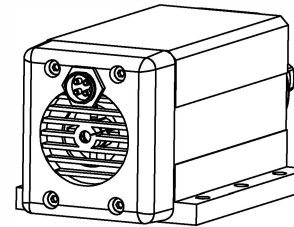
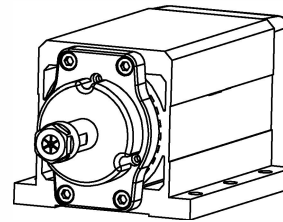
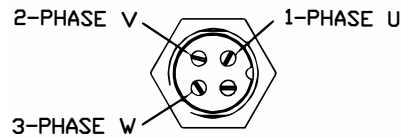

ROTATION: CCW VIEWED FROM OUTPUT SHAFT

MANUFACTUER MODEL	JK57BLS08-04
NUMBER OF POLES	4
PHASE TO PHASE RESISTANCE	0.61 OHMS
NOMINAL VOLTAGE	110 VAC
NO LOAD SPEED	13000±10% RPM
NO LOAD CURRENT	1.4 Amps Max.
RATED TORQUE	0.55 N-m
RATED SPEED	12000±10% RPM
OUTPUT POWER	691 W
BACK EMF CONSTANT	8.46 V/kRPM
TORQUE CONSTANT	0.081 N-m/A
INSULATION CLASS	B

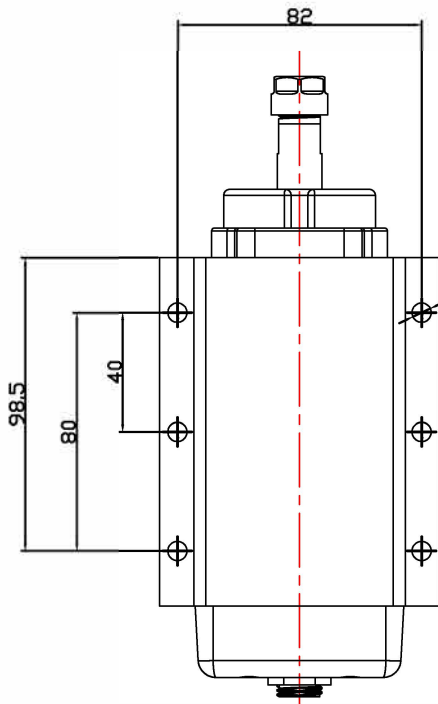

6-Ø6.5

ELECTRICAL CONNECTION TABLE

PHASE U	YEL	黄	UL1007 18AWG
PHASE V	GRE	绿	
PHASE W	BLU	蓝	

REV.	QTY.	No.	SIG.	DATE
DESIGN	21.08.05 STD.			
CHECK				
PROC.			APPR.	

Specification

CLS.MAK WEIGHT SCALE

PAGE: 1/1