USER'S MANUAL

TABLE OF CONTENTS

Page #

Contents

1.0	FEATURES	1-1
	• 34 Inputs and Outputs on 2 ports.....	1-1
	• Connects directly to the Smooth Stepper (from Warp9).....	1-1
2.0	SPECIFICATIONS	2-1
3.0	FUNCTIONAL BLOCK DIAGRAMS	3-1
	Inputs 10, 11, 12 13 and 15 (Port 1 and Port 2) simplified functional block diagram.....	3-1
	Inputs 2-9 (Port 2) simplified functional block diagram	3-1
	Outputs 1, 14, 16 and 17 (Port 1 and 2) and outputs 2-9 (port 1).	3-2
4.0	WIRING DIAGRAMS	4-2
	Connecting Switches or push button (Only for pins 2-9, port 2).	4-2
	Connecting Switches or push button (Pins 11, 12, 13 and 15, Ports 1 and 2).	4-3
	Connecting NPN sensors (For any input).....	4-3
	Connecting PNP sensors (For any input).....	4-6
	Other connection (For any input).....	4-6
5.0	DIMENSIONS	5-1
6.0	DISCLAIMER:	6-1

1.0 FEATURES

- **34 Inputs and Outputs on 2 ports.**
- ***Full access to all the pins of the Smooth Stepper Board.***
- **Connects directly to the Smooth Stepper (from Warp9).**

The board is provided with sockets that allow the Smooth Stepper Board to be plugged directly into this board. No ribbon cables required. When using the Smooth Stepper board there is no need to use an additional power supply to power the board. It will draw power from the Smooth Stepper board.
- ***Built-in Passive Low Pass Filters for the all inputs.***

This board includes low pass filters to reduce the effect of the noise from the drivers or other devices over the inputs signals.
- ***All TTL 5VDC signals.***

Interface directly with parallel port interface products and other CNC4PC cards. 5VDC (TTL) cards are very common among automation devices.
- ***Input and output pins with close by ground connections.***

Forget about grounding problems. Easily connect your pin by using your close by ground connection. No need to be an electronics expert to ground all your stuff.
- ***Screw-On connections for all terminals.***

You only have to screw-on the wires to make all your connections.

2.0 SPECIFICATIONS

DIGITAL INPUT SPECIFICATIONS	
Numbers of inputs	5 on Port1, 13 on Port2
On-state voltage range	3.5 to 5V DC
Maximum off-state voltage	Aprox. 1.5V
Type	Active High

DIGITAL OUTPUT SPECIFICATIONS	
Number of outputs	12 on Port1, 4 on port2
Maximum output voltage	(5V power supply voltage) + 0.5V
Maximum off-state voltage	0.33 V

3.0 FUNCTIONAL BLOCK DIAGRAMS

Inputs 10, 11, 12 13 and 15 (Port 1 and Port 2) simplified functional block diagram

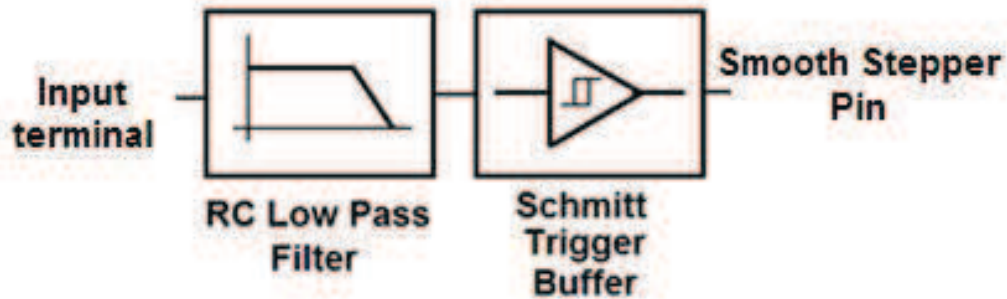

Simplified functional block diagram.

Note: The Smooth Stepper includes an Schmitt Trigger in those input pins.

Inputs 2-9 (Port 2) simplified functional block diagram

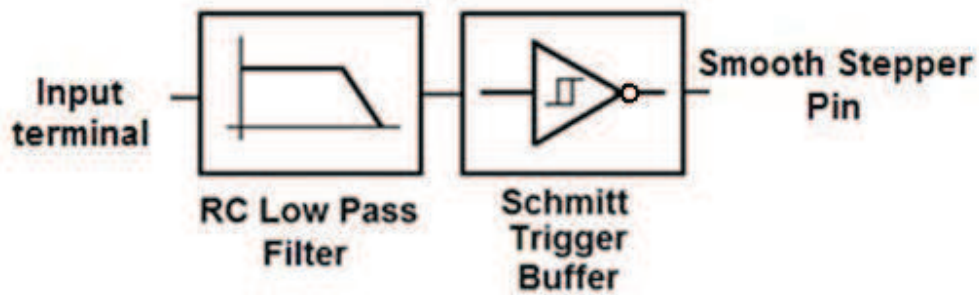

Simplified functional block diagram for the port 2 inputs 2-9.

Using an RC Low Pass filter followed by a Schmitt Trigger gate will reduce the effect of the noise from driver or other devices. This eliminates the high frequency components of the noise and generating a fast changing signal.

Outputs 1, 14, 16 and 17 (Port 1 and 2) and outputs 2-9 (port 1).

All those pins are directly routed to the C25 output terminals.

4.0 WIRING DIAGRAMS

Different kind of sensors and switches can be connected to inputs board, but this board support only TTL signal. If you need to connect devices that generates 12V or 24V signals in some cases is necessary add external resistors.

Connecting Switches or push button (Only for pins 2-9, port 2).

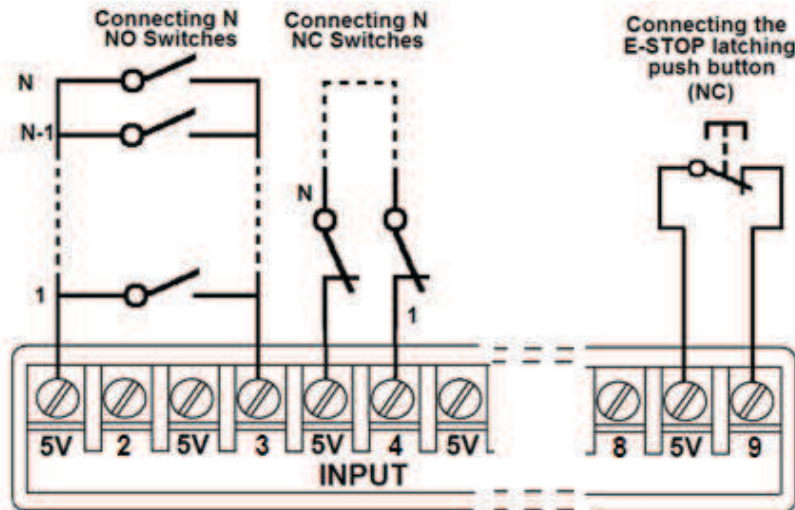

Connecting Switches or push button (Pins 11, 12, 13 and 15, Ports 1 and 2).

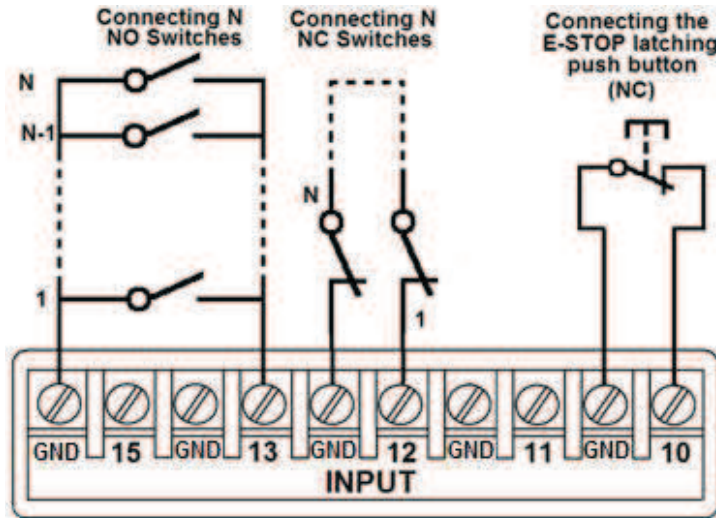

Wiring diagram to connect switches.

Connecting NPN sensors (For any input).

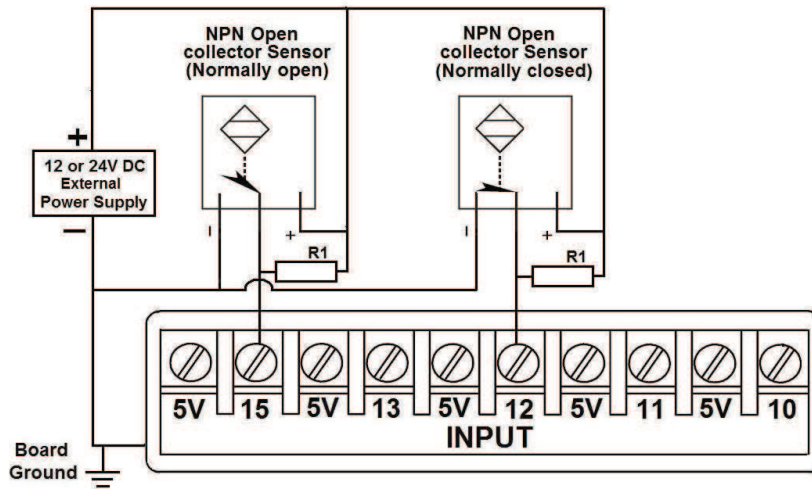

Wiring diagram to connect NPN open collector proximity sensors.

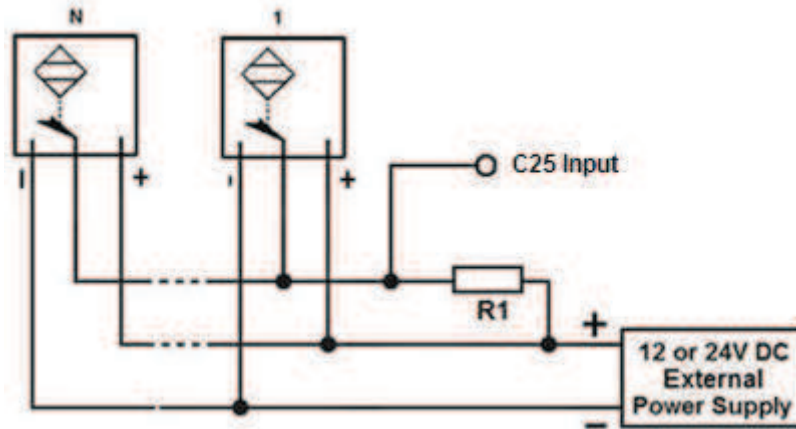

Wiring diagram to connect in parallel NPN open collector proximity sensors.

Connecting NPN open collector proximity sensor with the C25	
R1 Value (12V)	R1 Value (24V)
Aprox. 10K Ω	Aprox. 25K Ω

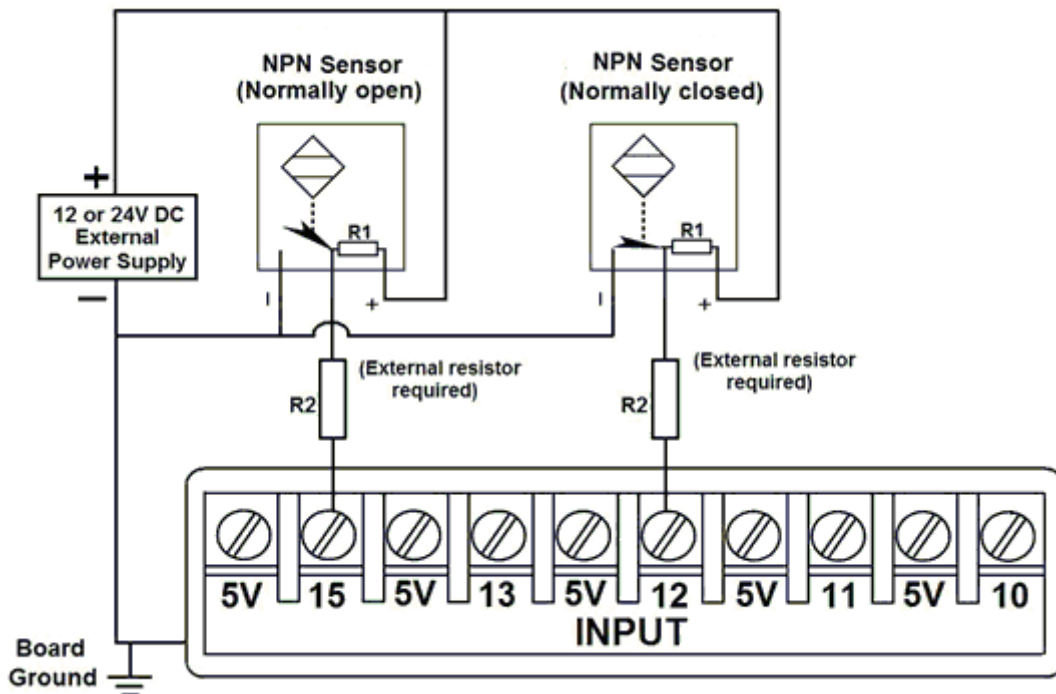

Wiring diagram to connect NPN proximity sensors with internal pull up resistor.

Some NPN proximity sensors have an internal pull-up resistor (R1). It is necessary to know its value in order to safely connect the sensor with the BOB. Follow this recommendation:

Connecting NPN open collector proximity sensor with the C25	
(R1+R2) Value (12V)	(R1+R2) Value (24V)
Aprox. 10KΩ	Aprox. 25KΩ

Calculating the R1 value.

Note: Rx is the unknown resistor value.

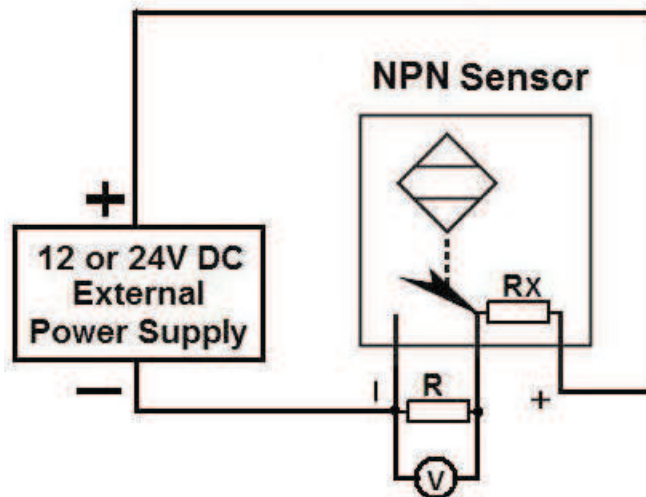

$$R_x = V_{EX} \cdot (R/V) - R \quad (1)$$

Where:

V_{EX} is the external power supply voltage

V is the voltage across the R resistor

A voltmeter is required to calculate the internal resistor value (Rx). Do the connection as are shown in the figure above and do the calculations using the equation (1).

Note. R value has to be known to do this operation. A 4.7KOhm@1/2W is recommended.

For example, if you are using a 12V power supply (V_{EX}), and use a 4.7KOhm as external resistor (R), and the voltage across R is 6V, using the equation 1, the Rx value is 4.7KOhm.

Connecting PNP sensors (For any input).

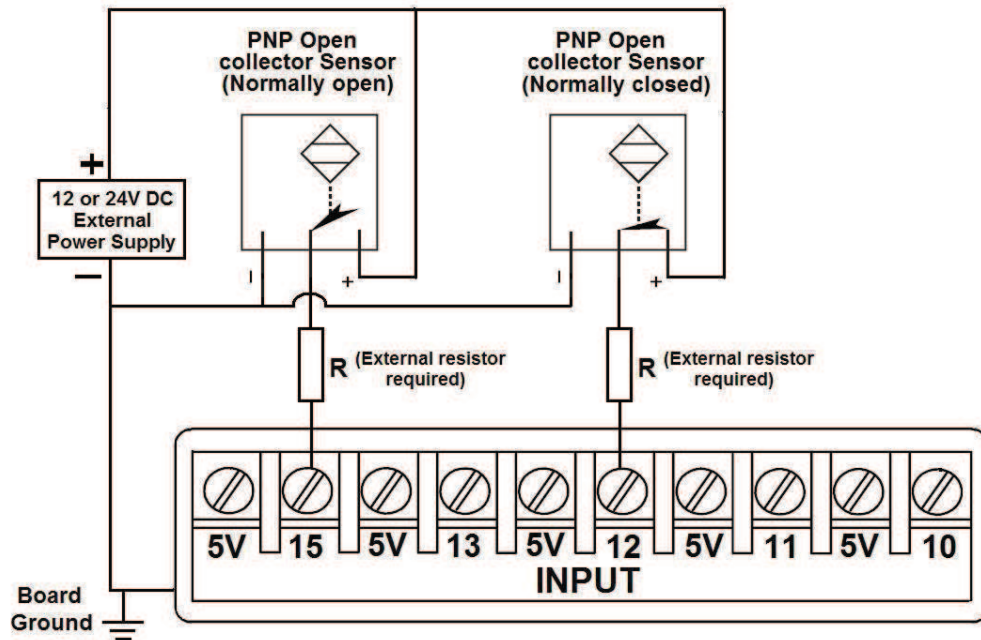

Fig. 10 Wiring diagram to connect PNP proximity sensors

Connecting PNP proximity sensor with the C25	
R Value (12V)	R Value (24V)
Aprox. 10KΩ	Aprox. 25KΩ

Other connection (For any input).

Other connections can be implemented by setting the inputs with pull-up resistor. In this case connect an external 4.7KOhm resistor between the input terminal and the 5V terminal.

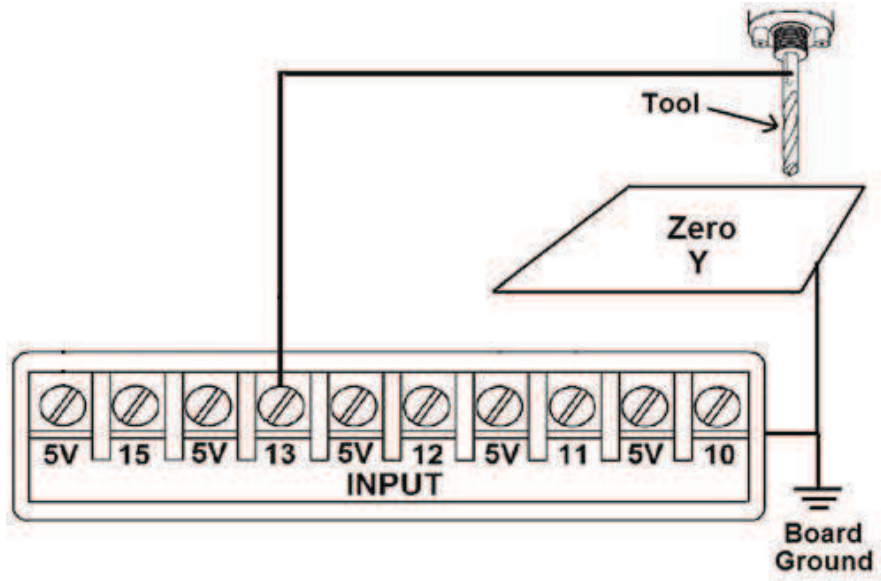
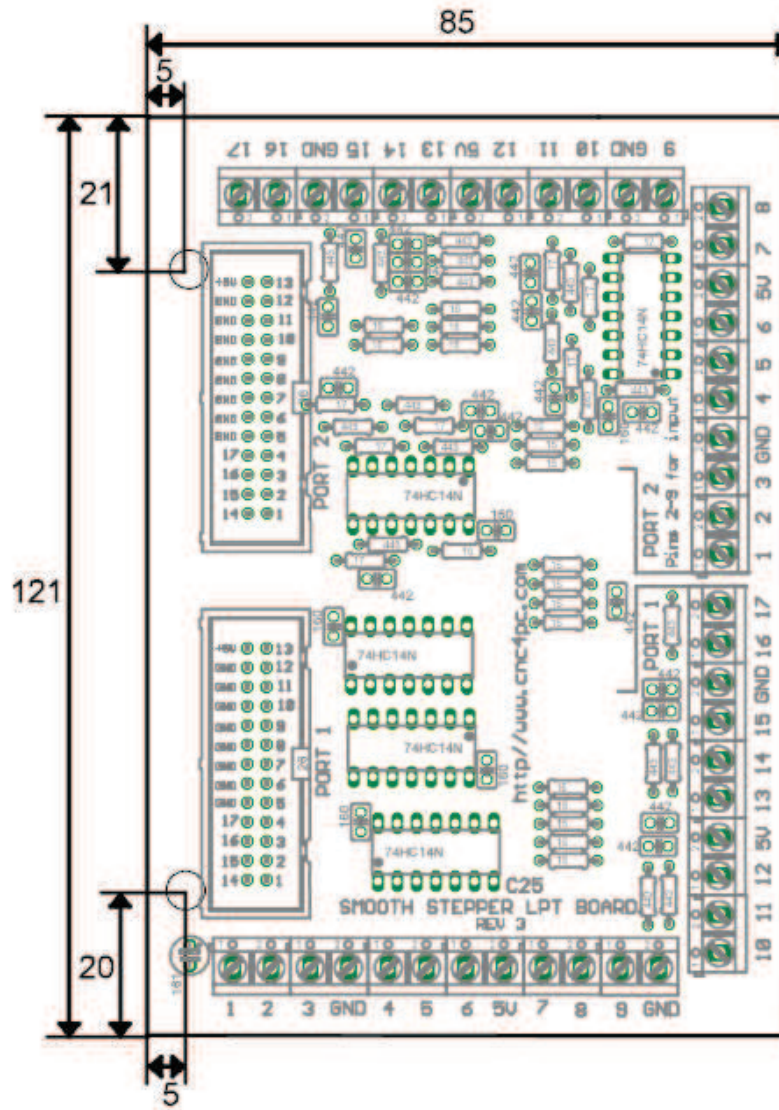

Fig. 11 Wiring diagram to do an "Auto Tool Zero"

5.0 DIMENSIONS



All dimensions are in Millimeters.

6.0 DISCLAIMER:

Use caution. CNC machines could be dangerous machines. DUNCAN USA, LLC or Arturo Duncan are not liable for any accidents resulting from the improper use of these devices. This product is not fail-safe device, and it should not be used in life support systems or in other devices where its failure or possible erratic operation could cause property damage, bodily injury or loss of life.